

MEDENUS



Gas Pressure Regulation



Gas Pressure Regulator R105

Product information



EN

Table of content

Application, characteristics, technical data	4
Application	4
Characteristics	4
Type of models / Options (see page 12)	4
Accuracy class AC / Closing pressure group SG	4
Technical data	5
Structure and function	6
Installation example	6
Sectional view	7
K_G^* value and diaphragm assemblies	8
RE - Diaphragm assembly	8
Diaphragm assembly setpoint spring table	9
Dimensions, connection, and weight	10
Dimensional drawing	10
Dimensions and weight	11
Connection of the measuring lines and breather lines	11
Types of models / Options	12
Design	14
Calculation of the required K_G value	14
Device selection	14
Checking the gas velocities	14
Properties of gases	15
Order data	16
Contact	17
Notes	19



ATTENTION

Observe the following publications in relation to installation, start-up and maintenance:
 DVGW - work sheets G 491 and G 600
 Operating and Maintenance Instructions R 105

List of abbreviations and formula symbols

AC	Accuracy class	$p_{ds\ o}$	Upper SSV response pressure	$W_{ds\ o}$	Upper spring adjustment range (SSV)
AG_o	Upper response pressure group	$p_{ds\ u}$	Lower SSV response pressure		
AG_u	Lower response pressure group	$p_{f,max}$	Maximum closing pressure	$W_{ds\ u}$	Lower spring adjustment range (SSV)
BV	Breather valve	PS	Maximum allowable pressure	Δp	Pressure difference from inlet pressure to outlet pressure
GPR	Gas pressure regulator	p_u	Inlet pressure		
HDS	High-pressure spindle	Q_n	Standard volumetric flow rate	Δp_{wo}	Min. re-engagement difference between upper response pressure and normal operating pressure
K_G	Valve flow rate coefficient	RE	Diaphragm assembly		
p	Pressure	RSD2	Throttle valve	Δp_{wu}	Min. re-engagement difference between lower response pressure and normal operating pressure
p_d	Outlet pressure	SSV	Safety shut-off valve		
p_{df}	SRV closing pressure	SRV	Safety relief valve	ρ_n	Gas density
p_{do}	SRV opening pressure	SG	Closing pressure group		
p_{ds}	Setpoint of the response pressure	t_{Gas}	Gas inlet temperature		
		VS	Valve seat		
		w_d	Outlet gas velocity		
		w_u	Inlet gas velocity		

*) K_G value for natural gas

Application, characteristics, technical data

Application

Gas pressure regulator (GPR), direct-acting (operating without auxiliary power), for systems acc. to DVGW Code of Practice G 491 (A) and G 600 (A) (TRGI)

Particularly suitable for dynamic regulation sections (e.g. gas fireplaces, burner circuits, gas motor operation).

Can be used as an equipment component on gas consumption facilities as defined in Regulation (EU) 2016/426.

Can be used for the gases defined in DVGW Code of Practice G 260 / G 262 and neutral non-aggressive gases.

(other gases on request)

Characteristics

- Integral pressure-tight model (IS)
- Easy maintenance through replaceable functional units (modular design)
- Open-air model

Type of models / Options (see page 12)

- Diaphragm assembly optionally with safety diaphragm
- With noise reduction
- With throttle valve (RSD2) for impulse line of the regulator
- Oxygen model ($p_u \leq 10$ bar)
- Hydrogen version
- Coating with epoxy resin in RAL colors

Accuracy class AC / Closing pressure group SG

Outlet pressure range P_d , minimum pressure differential 100 mbar	Diaphragm assembly							
	160	205	275	275-2	330	385	390	485
18 mbar to 100 mbar					10 / 20	10 / 20	10 / 20	5 / 10
90 mbar to 500 mbar			5 / 10					
100 mbar to 500 mbar					5 / 10	5 / 10	5 / 10	5 / 10
350 mbar to 500 mbar				10 / 20				
500 mbar to 1000 mbar	10 / 20	10 / 20						
> 500 mbar			2.5 / 10	5 / 10	2.5 / 10	2.5 / 10	2.5 / 10	
> 1000 mbar	5 / 10	5 / 10						

Technical data

Type	R105
Model	Integral pressure-tight (IS)
Max. allowable pressure PS	16 bar
Max. inlet pressure $p_{u,max}$	16 bar
Nominal width	DN 25, DN 40, DN 50, DN 65, DN 100
Connection type	DIN EN 1092 flanges PN 16 / ASME - B16.5 flanges Class 150 RF
Material Housing / actuator housing/ control device housing	Al cast alloy
Corrosivity category C1 to C5-I C5-M	DIN EN ISO 12944-2 without additional coatings an epoxy resin coating is recommended (see page13)
Temperature range, Class 2 (operating/ambient temperature)	-20°C to +60°C
Closing pressure zone group	SZ 2.5
Function, strength, and tightness CE mark to PED/ PIN number	DIN EN 334 and DIN EN 14382 CE-0085-AQ0882 / CE-0085-AQ0883
Ex protection	The mechanical parts of the device do not have any potential ignition sources of their own and therefore do not fall within the scope of ATEX 95 (94/9/EC). Electrical components fitted to the device comply with the ATEX requirements.

Preferred installation position

The gas pressure regulators R105 shall be installed in the pipeline preferably in horizontal position. For all nominal widths, the direction of flow is indicated by an arrow on the housing.



Overhead installation position only after consultation with Medenus GmbH

Note: Observe the following documents in relation to installation, start-up, and maintenance:

- DVGW - work sheets G 491 and G 600
- Operating and Maintenance Instructions R 105

Structure and function

The spring-loaded gas pressure regulator R105 has the function of keeping the outlet pressure of a gaseous medium constant within allowable limit values in the connected regulation section on the outlet side, independently of the effect of interferences, such as changes in the inlet pressure and/or in the gas tap. The gas pressure regulator is composed of the actuator housing and the "diaphragm assembly plus actuator".

The actuator for the diaphragm assembly can be produced in various valve seat diameters to suit different nominal widths. The gas flows through the actuator housing in the direction of the arrow. The external measurement line port is used to pass the outlet pressure to be regulated to the bottom of the main diaphragm of the diaphragm assembly. It compares the actual value with the command variable preset by the force of the setpoint spring. The setpoint required in each case is set via the setting screw. Any deviation from the setpoint is transmitted by the screw spindle to the actuator, which is adjusted in a way that the actual value is adjusted to the setpoint. In case of zero tap, the actuator will close tight, causing the closing pressure to be established.

Installation example

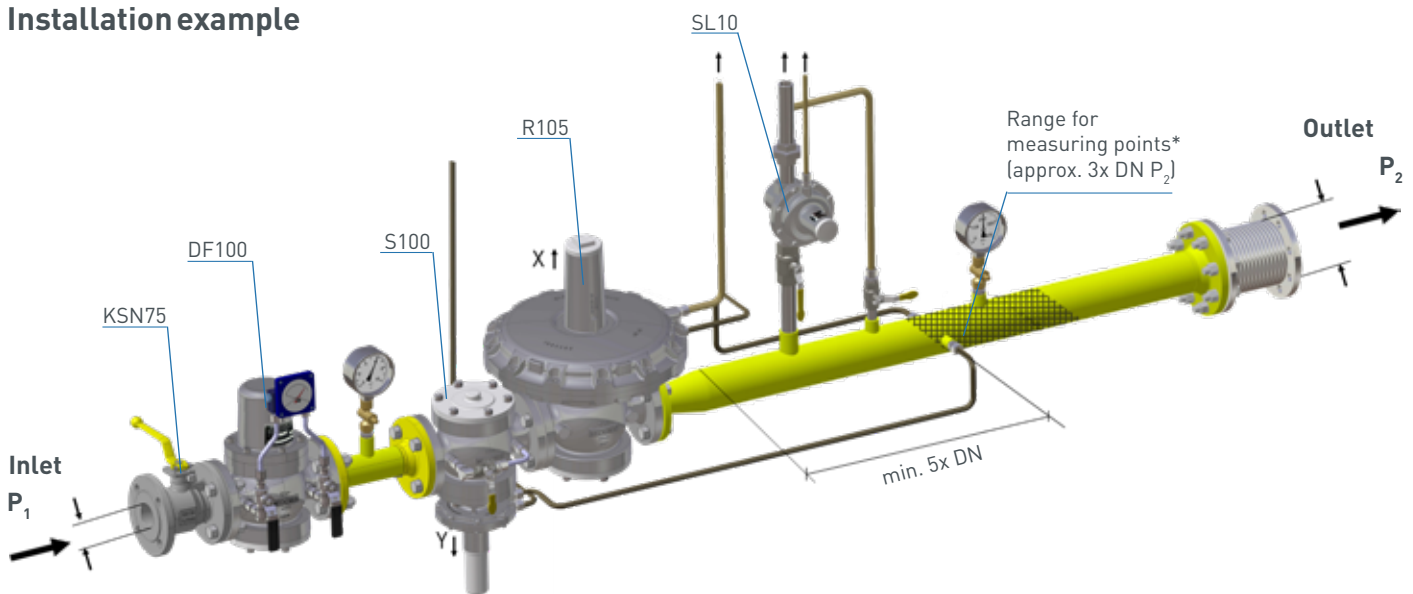

*) Recommended max. velocity at the measurement line port 25 m/s

Sectional view

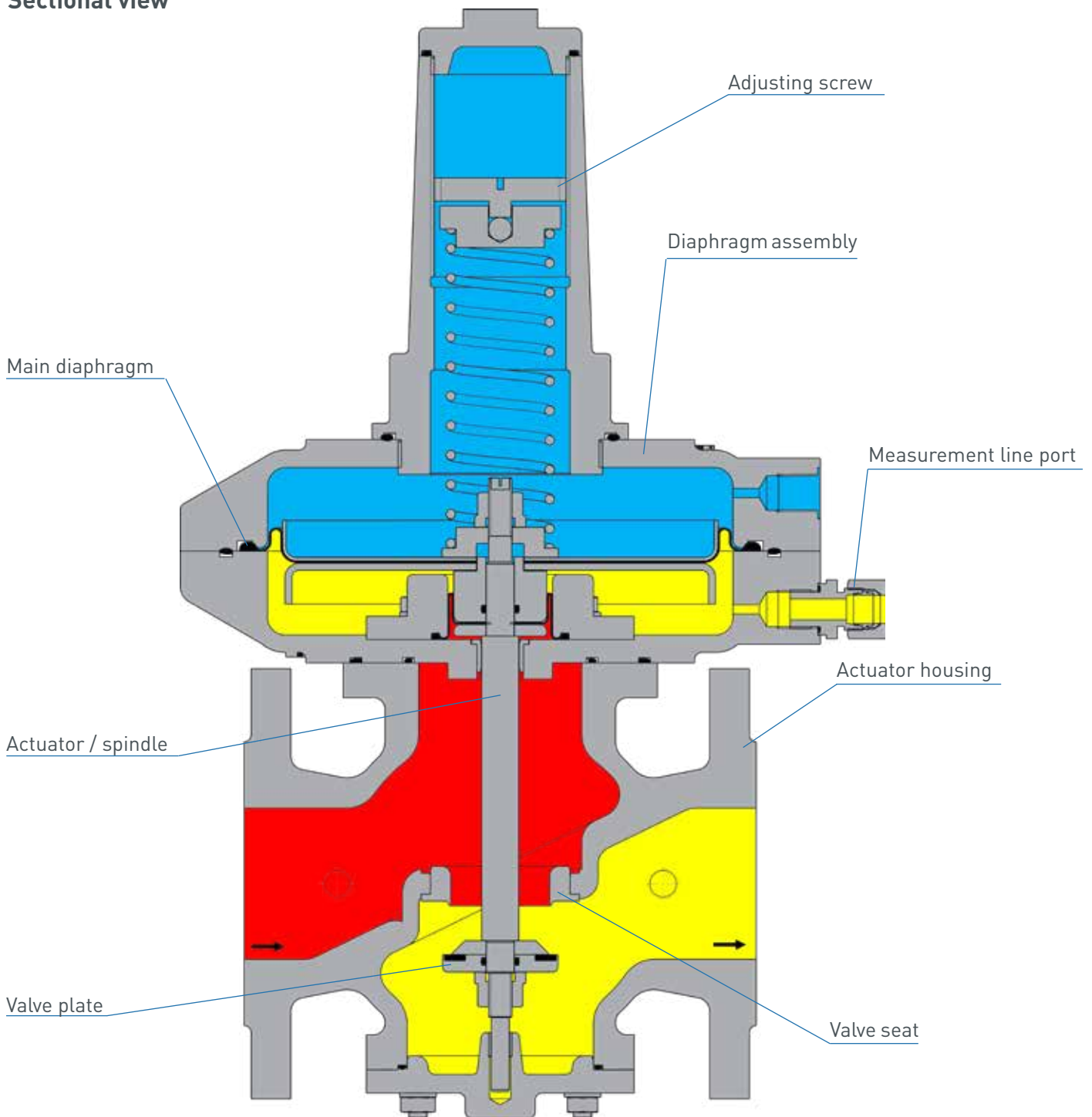

K_G* value and diaphragm assemblies

		R 105				
Nominal width		DN 25	DN 40	DN 50	DN 65	DN 100
Diaphragm assembly Ø		160	160	205	205	275-2
		205	205	275	275	385
Valve seat Ø		330	330	390	390	485
17.5 mm		200	220			
27.5 mm		460	600			
32.5 mm			750	1000	1000	
42.5 mm				1500	1500	
52.5 mm				1800	1800	
65.0 mm						3500
95.0 mm						5800
Connection type		DIN 1092 - PN16				

*) K_G value for natural gas: $\rho_n = 0.83 \text{ kg/m}^3$, $t_u = 15^\circ\text{C}$

RE - Diaphragm assembly

Regulator type Nominal width	Nominal width	Diaphragm assembly	Outlet pressure ranges [mbar]	Outlet pressure range with high-pressure spindle HDS [mbar] (illustration with HDS on p. 12)
R105	DN 25	RE 330	22 - 200	200 - 800
		RE 205	200 - 750	750 - 3000
		RE 160	750 - 1200	-
	DN 40	RE 330	22 - 200	200 - 800
		RE 205	200 - 750	750 - 3000
		RE 160	750 - 1200	-
	DN 50	RE 390	22 - 130	130 - 450
		RE 275	130 - 400	400 - 1100
		RE 205	400 - 750	750 - 3000
	DN 65	RE 390	22 - 130	130 - 450
		RE 275	130 - 400	400 - 1100
		RE 205	400 - 750	750 - 3000
	DN 100	RE 485	22 - 150	150 - 450
		RE 385	150 - 350	350 - 850
		RE 275-2	350 - 850	850 - 3000

Diaphragm assembly setpoint spring table

Specific command range W_{ds} [mbar]					Spring data	
RE 160	RE 205	RE 275	RE 330	RE 390	Feder- Nr.	Farbe [RAL]
-	-	-	22 - 29	-	FA 05	7037
-	-	-	28 - 39	22 - 24	FA 06	9005
-	-	-	38 - 54	23 - 32	FA 07	3020
-	-	-	53 - 77	31 - 45	FA 08	9010
-	200 - 295	130 - 156	76 - 111	42 - 64	FA 09	7016
750 - 899	280 - 430	141 - 225	130 - 166	59 - 94	FA 10	6010
802 - 1371	419 - 653	208 - 339	165 - 250	88 - 142	FA 11	2002
1143 - 1200	595 - 935	293 - 484	239 - 361	124 - 203	FA 12*	7035
-	819 - 1408	436 - 726	360 - 544	185 - 305	FA 13*	5010
-	1245 - 1976	607 - 1017	506 - 765	258 - 428	FA 14*	1028
-	1212 - 2553	699 - 1100	535 - 800	297 - 450	FA 15*	6018
-	1330 - 3000	-	-	-	FA 16*	3020

* High-pressure spindle HDS required (illustration p. 12)

Specific command range W_{ds} [mbar]			Spring data	
RE 275-2	RE 385	RE 485	Feder- Nr.	Farbe [RAL]
-	-	22 - 25	FB 702	9006
-	-	24 - 31	FB 703	5015
-	-	28 - 36	FB 704	4002
-	-	33 - 44	FB 705	7037
-	-	41 - 56	FB 706	9005
-	-	51 - 71	FB 707	3020
-	150 - 167	65 - 94	FB 708	9010
350 - 450	165 - 215	82 - 118	FB 709	7016
397 - 596	212 - 285	105 - 155	FB 710	6010
542 - 814	280 - 390	140 - 209	FB 711	2002
742 - 1078	385 - 520	188 - 275	FB 712	7035
977 - 1442	515 - 671	246 - 369	FB 713*	5010
1245 - 1878	661 - 850	311 - 450	FB 714*	1028
1547 - 2469	-	-	FB 715*	6018
2136 - 3000	-	-	FB 716*	3020

* High-pressure spindle HDS required (illustration p. 12)

Dimensions, connection, and weight

Dimensional drawing

Dismounting dimensions for springs

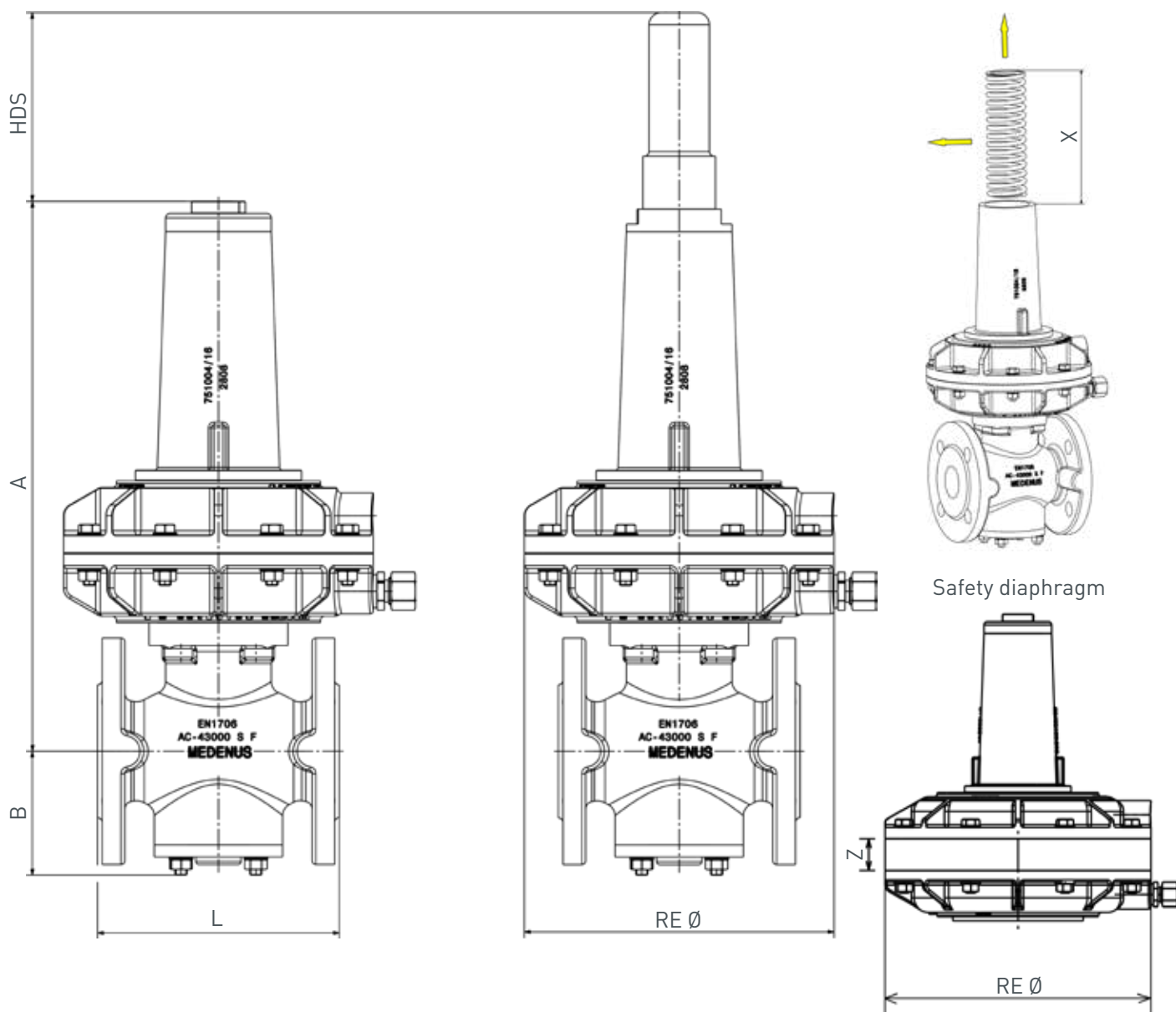

Dimensions and weight

Dimensions	Nominal width RE Ø	R 105				
		DN 25	DN 40	DN 50	DN 65	DN 100
A [mm]	160	356	356	-	-	-
	205	364	364	408	376	-
	275	-	-	408	376	661
	320	346	346	-	-	-
	385/390	-	-	408	376	661
	485	-	-	-	-	661
HDS [mm]		125	125	125	125	205
B [mm]		84	84	115	101	188
L [mm]		160	160	250	220	350
X [mm]		210	210	210	210	410
Z [mm]		32.5	32.5	32.5	32.5	32.5
Weight						
Weight [kg]	160	6.5	7.5	-	-	-
	205	8	9	16	16	-
	275	-	-	18	18	38
	320	10.5	11	-	-	-
	385/390	-	-	22	22	43
	485	-	-	-	-	53
SM safety diaphragm weight [kg]	205	2	2	2	2	-
	275	-	-	3	3	3.3
	320	3	3	-	-	-
	385/390	-	-	5	5	6
HDS weight [kg]		0.6	0.6	0.6	0.6	1.6
Connection		DIN 1092 - PN16				

Example: R105/050/390 with HDS and safety diaphragm

Weight (regulator + HDS + SM): 16 kg + 0.6 kg + 5 kg = 21.6 kg

Dimensions (A + HDS + SM): 408 mm + 125 mm + 32.5 mm = 565.5 mm

Connection of the measuring lines and breather lines

Nominal width	Diaphragm assembly	
	Measurement line	Breather line
DN 025	Connection* for: Tube 12 x 1.5 (thread G 3/8)	
DN 040		
DN 050		
DN 065		
DN 100		

Types of models / Options

Safety diaphragm

In the model with safety diaphragm, the safety diaphragm is located above the main diaphragm. When the main diaphragm is damaged, the safety diaphragm makes contact with the top cover of the diaphragm assembly and limits any inadmissible escape of gas into the surrounding atmosphere to a maximum of 30l/h (air).



(Option not available for hydrogen version H₂)

Noise reduction

The noise reduction made of metallic foam reduces noise in the gas pressure regulator produced by the flow rate by up to -15 dB (±3 dB).

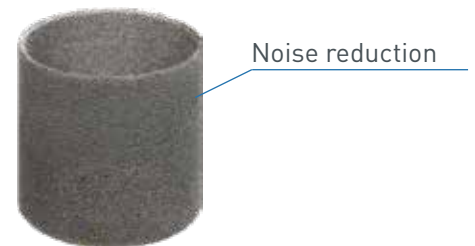

RSD2 throttle valve

The RSD2 is a throttle valve which regulates the volume flow in the sensing/impulse line by means of a continuously adjustable cross-sectional reduction. The setting is made tool-free by means of a rotary knob and can be adjusted using a screw to be fixed. The throttle valve cannot be completely shut off, therefore a guaranteed minimum flow is ensured.



High-pressure spindle HDS

The high pressure spindle (HDS) is used to adjust the control spring at high outlet pressure. (See spring tables p. 9)



Epoxy resin coating in RAL colors

To protect the gas pressure regulator from external influences, starting from a corrosivity category C5-M we recommend an epoxy resin coating.



Types of models

Oxygen model O_2

Hydrogen version H_2 (with helium leak test)

The Medenus gas pressure regulators are suitable for use with hydrogen as a medium up to a proportion of 100%.

Further information can be found in the special edition (10/2019) of gwf Gas+Energie and on our homepage at (www.medenus.de).



AV breather valve

The AV breather valve is used to secure the installation room against inadmissible escape of gas from diaphragm comparator compartments of safety shut-off valves. In case of a defect, the impermissible escape of gas into the surrounding atmosphere is limited to a maximum of 30l/h (air).

It also serves as a substitute for an expensive and complex installation of breather lines.

(Option not available for hydrogen version H_2)



AV breather valve

Design

Note All calculated pressures are absolute pressures. (p+1 bar)
The required KG value for a gas pressure regulator is determined with the smallest inlet pressure or lowest pressure drop.

Calculation of the required K_G value

$$\begin{aligned} p_d / p_u > 0.5 \\ K_G \text{ value at} \\ \text{a subcritical pressure ratio} \\ K_G = Q_n / \sqrt{p_d \cdot (p_u - p_d)} \end{aligned}$$

$$\begin{aligned} p_d / p_u \leq 0.5 \\ K_G \text{ value at} \\ \text{a supercritical pressure ratio} \\ K_G = 2 \cdot Q_n / p_u \end{aligned}$$

Note For spring-loaded devices, a capacity reserve of 10-20% is recommended in order to comply with the accuracies given.

The device is selected on the basis of its K_G value from the table of flow rate coefficients (page 8)

Device selection

Note Closing pressure zone group: SZ 2.5

For the small load Q_{min} with SZ this yields 2.5: $Q_{min} = 0.025 \cdot K_G \cdot p_{u \max}$

Small load Q_{min} - When burner is started or at Q_{min} a K_G utilization level of at least 1% should be reached.

Selection of the diaphragm assembly from the diaphragm assembly setpoint spring table (page 9)

Selection of the closing pressure group from the closing pressure group table (page 4)

$$p_{f \max} = p_{ds} \cdot (1 + SG/100)$$

Checking the gas velocities

$$w = 380 \cdot Q_n / (DN^2 \cdot p_{abs})$$

Note The factor 380 refers to an operating gas temperature from approx. 15°C to 20°C. For other temperatures, the velocity must be corrected as follows:
 $w_{corr} = w \cdot (t_{gas} + 273.15) / 290$

Recommended max. gas velocity at the inlet flange:

50 - 70 m/s lower value for redirections upstream of the control valve, 20 m/s for upstream filters

Recommended max. gas velocity at the outlet flange:

100 - 200 m/s lower value to reduce noise emissions

Recommended max. gas velocity on impulse tap: 15 - 25 m/s

15 m/s max. value for outlet pressures below 100 mbar

The device selected in the example of nominal width DN 50 can be operated under these conditions.

p_u Inlet pressure (bar)
 p_d Outlet pressure (bar)
 Q_n Standard volumetric flow rate (Nm³/h)

Example: Overpressure Absolute pressure

$p_{u \min}$ 5.0 bar 6.0 bar
 $p_{d \min}$ 0.5 bar 1.5 bar
 $Q_{n \min}$ 1500 m³/h

1.25 bar / 6 bar = 0.25 < 0.5
→ Supercritical pressure ratio
 $K_G = 2 \cdot 1500 / 6 = 500 \text{ m}^3/(\text{h} \cdot \text{bar})$

Selected device

Type R 105
DN - Nominal width 050
D - Nozzle V 32.5
 K_G value 750 m³/(h*bar)

$$Q_{min} = 0.025 \cdot 750 \cdot 9 = 169 \text{ m}^3/\text{h}$$

Selected diaphragm assembly

RE - Diaphragm assembly 330
Setpoint spring FA13
(W_{ds} 300-600)

AC 5/SG 10 (for RE 330 D - Nozzle 32.5)

Nominal width of input and output of pipeline according to the selected device: 50 mm
Selected widening of outlet pipeline: 150 mm

$$w_u = 380 \cdot 1500 / (50^2 \cdot 14) = 38 \text{ m/s}$$

$$w_d = 380 \cdot 1500 / (50^2 \cdot 1.5) = 152 \text{ m/s}$$

$$w_{impulse} = 380 \cdot 1500 / (200^2 \cdot 1.5) = 17 \text{ m/s}$$

Properties of gases

- for natural gas ($\rho_n = 0.83 \text{ kg/m}^3$; $t = 15^\circ\text{C}$)
- f - natural gas L conversion factor

Gas	f	Hs,n [kWh/m ³]	Gas	f	Hs,n [kWh/m ³]
Acetylene	0.84	16.25	Sewage gas	0.84	
Ammonia	1.04	4.83	Carbon monoxide	0.81	3.51
Butane	0.55	37.23	Carbon dioxide	0.65	-
Chlorine	0.51	-	Air	0.80	-
Landfill gas	approx. 0.80		Methane	1.08	11.06
Natural gas L	1.00	9.77	Propane	0.64	28.03
Natural gas H	1.03	11.45	Oxygen	0.76	-
Ethane	0.78	19.55	Sulphur dioxide	0.53	-
Ethylene	0.97	16.516	Nitrogen	0.81	-
Mine gas (30% CH ₄)		0.86	Hydrogen	3.04	13.43
Helium	2.15	-			

Notes

.....

.....

.....

.....

.....

.....

.....

.....

.....

.....

.....

.....

.....

.....

.....

.....

.....

.....

.....

.....

.....

.....

.....

.....

.....

.....

Order data

(In every selection group, only one option can be selected in each case)

Example:

Gas pressure regulator: R105/050/205/32.5/HDS/links/SR/SM/RSD2/WAZ/So

		Order code:												
		R 105	050	-	205	32.5	HDS	left	SR	SM	RSD2	WAZ	So	
Order selection	Designation													
Type														
R 105	R 105	R 105												
DN - Nominal width	Table p. 14		050											
Flange model														
PN 16	-													
Class 150	C													
RE - Diaphragm assembly	Table p. 15				205									
D - Nozzle (valve seat diameter)	Table p. 15					32.5								
High-pressure spindle	Fig. p. 12													
without high-pressure spindle	-													
with high-pressure spindle	HDS							HDS						
Direction of flow														
Right (from left to right)	-													
Left (from right to left)	left								left					
Noise reduction	Fig. p. 12													
without noise reduction	-													
with noise reduction	SR									SR				
Additional unit, diaphragm assembly	Fig. p. 12													
without additional unit, diaphragm assembly	-													
Safety diaphragm	SM										SM			
Throttle valve	Fig. p. 12													
without throttle valve	-													
with throttle valve	RSD2											RSD2		
Acceptance test certificate to EN 10204/3.1														
without acceptance test certificate	-													
with acceptance test certificate	WAZ												WAZ	
Special model	So													So
- Coating with epoxy resin in RAL colors Oxygen model														

Contact



Management
ALEXANDER CHRISTIANI

Phone: +49 (0) 2761 / 82788-18
Mail: a.christiani@medenus.de



Technical Inside Sales Department
MINDAUGAS PECKAITIS

Phone: +49 (0) 2761 / 82788-23
Mail: m.peckaitis@medenus.de



Head of Inside Sales Department
MANUEL SCHEPP

Phone: +49 (0) 2761 / 82788-20
Mobile phone: +49 (0) 170 / 6355309
Mail: m.schepp@medenus.de



Inside Sales Department
SEBASTIAN HUCKESTEIN

Phone: +49 (0) 2761 / 82788-11
Mail: s.huckestein@medenus.de



Inside Sales Department
STEFANIE MÜLLER

Phone: +49 (0) 2761 / 82788-13
Mail: s.mueller@medenus.de



If you want to know more about solutions from MEDENUS for the gas industry, please contact your local contact person or go to our internet site at www.medenus.de

Trade representation worldwide
medenus.de/de/kontakt.html

MEDENUS
Gas-Druckregeltechnik GmbH

Im Langen Feld 3
D-57462 Olpe
Phone: +49 (0)2761 82788-0
Fax: +49 (0)2761 82788-9
Mail: info@medenus.de
Internet: www.medenus.de



THE MEDENUS PLUS

10 reasons for good business relations

1. Consultancy expertise and quality standards developed over decades
2. Broad and proven standard range of feedback controllers
3. Modern, fast and efficient production for series products and for individual orders
4. Customer-specific design of pressure regulators and vacuum regulators and special designs
5. Guaranteed deadline compliance with a delivery deadline guarantee
6. Fast response time in all matters
7. Sufficiently large parts storage for production and spare parts
8. Customer-specific theory & practice training courses
9. Modular design right across the entire product range to facilitate optimized handling of spare parts
10. 100% Made in Germany



MEDENUS Gas-Druckregeltechnik GmbH

Phone +49 (0)2761 82788-0

Fax +49 (0)2761 82788-9

Im Langen Feld 3 / D-57462 Olpe

info@medenus.de

www.medenus.de

EN